

BILL50

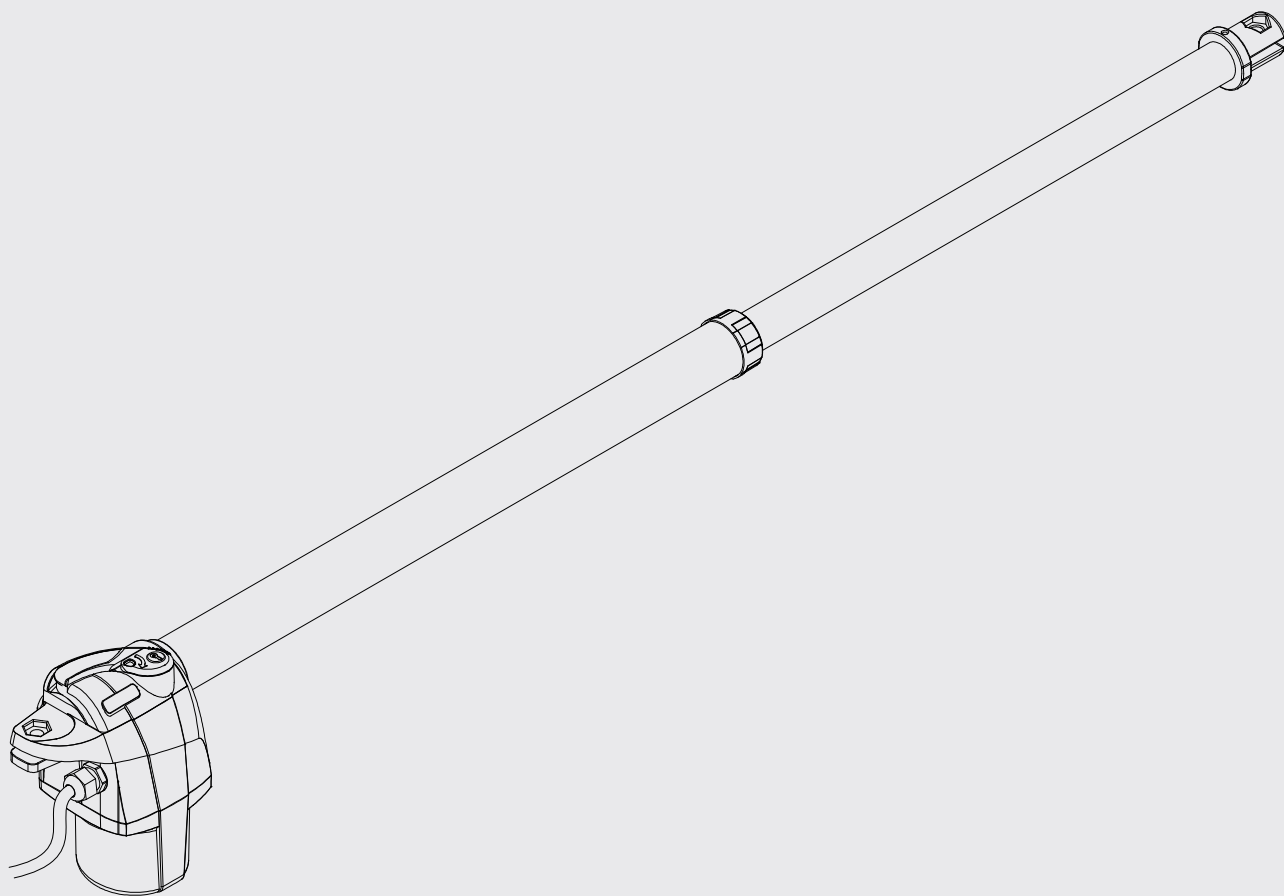

BENINCA[®]
TECHNOLOGY TO OPEN



AVVERTENZE - WARNING - HINWEISE ATTENTION - ADVERTENCIAS - OSTRZEŻENIA

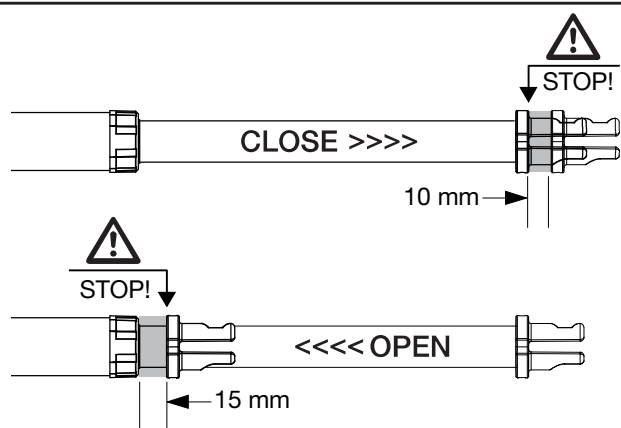

E' obbligatorio lasciare un'extra corsa di 10mm in chiusura e 15mm in apertura per evitare che lo stelo vada in battuta meccanica all'interno del tubo. Rispettare le quote di installazione indicate in Figura 3.

An extra-stroke of 10 mm in the closing phase and of 15mm in the opening phase are required in order to avert that the rod hits the inside of the tube. Keep to the installation dimensions shown in Fig. 3.

Einen Extrahub von 10 und 15 mm muss beim Öffnen bzw. beim Schließen laut Vorschrift vorgesehen werden, um zu vermeiden, dass der Schaft im Inneren des Rohrs anschlagen kann. Die Installationsmaße der Abbildung 3 einhalten.

Il est obligatoire de laisser une course extra de 10 mm en fermeture et de 15 mm en ouverture à fin d'éviter que la tige aille en buté mécanique à l'intérieur du tube. Respecter les côtes d'installation indiquées dans la Figure 3.

Es obligatorio dejar una carrera extra de 10mm en cierre y de 15mm en apertura para evitar que el vástago vaya a tope mecánico dentro del tubo. Se deben respetar las cotas que se indican en la Figura 3.

Należy obowiązkowo pozostawić extra skok o wymiarze 10mm podczas zamykania i 15mm podczas otwierania, aby zapobiec mechanicznemu uderzeniu trzpienia wewnątrz rury. Przestrzegać nastaw instalacyjnych podanych na Rysunku 3.

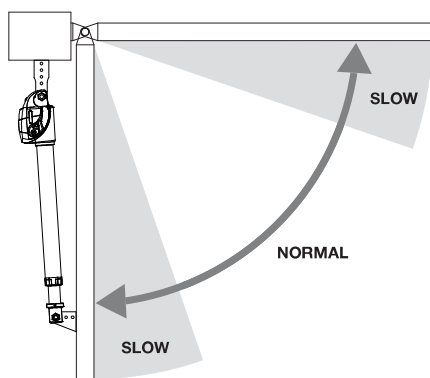

E' obbligatorio utilizzare i rallentamenti in apertura e chiusura.

Braking in both opening and closing operations is mandatory.

Die Geschwindigkeitsabnahme beim Öffnen und Schließen ist vorgeschrieben.

Il est obligatoire d'utiliser les ralentissements en phase d'ouverture et de fermeture.

Es obligatorio utilizar las ralentizaciones para la apertura y para el cierre.

Należy obowiązkowo użyć funkcji spowalniania podczas otwierania i zamykania.

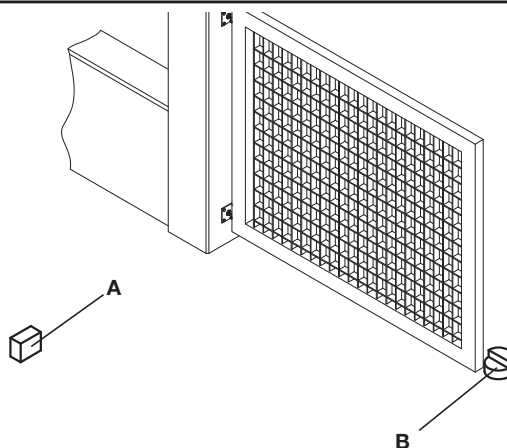

E' indispensabile che l'anta sia provvista di fermi meccanici a terra (rif. A e B).

It is mandatory that the gate leaf be equipped with mechanical stoppers fitted to the ground (ref. A and B).

Der Flügel muss jedoch mit mechanischen Anschlägen am Boden versehen sein (Ref. A und B).

Il est nécessaire que le vantail soit muni de butés d'arrêt à terre (réf. A et B).

Es indispensable que la hoja tenga topes mecánicos en el suelo (ref. A y B).

Należy wyposażyć skrzydło bramy w mechaniczne ograniczniki usytuowane w podłożu (odn. A i B).

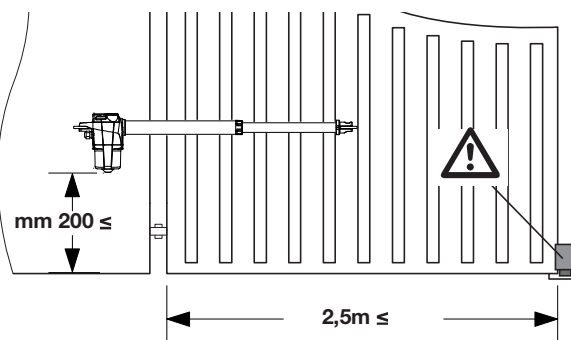

Altezza minima da terra: 200mm.

E' indispensabile l'elettroserratura nel caso di ante normali superiori ai 2.5m e nel caso di ante piene superiori ai 2.0m.

Minimum height from ground: 200mm.

The electric lock is essential in the event of standard gate leaves wider than 2.5m and of solid gate leaves wider than 2.0m.

Mindesthöhe vom Boden: 200mm.

Bei normalen Flügeln und einer Länge von 2,5 m oder bei vollen Flügeln und einer Länge von 2,0 m ist ein Elektroschloss erforderlich.

Hauteur minimum du sol: 200mm.

La serrure électrique est indispensable en cas de vantaux normaux de hauteur supérieur à 2.5m, ainsi que dans le cas de vantaux pleins de plus de 2.0m de hauteur.

Altura mínima con respecto al suelo: 200 mm.

Es indispensable la cerradura eléctrica en caso de hojas normales largas más de 2,5 m y en caso de hojas macizas largas más de 2,0 m.

Minimalna wysokość od podłoża: 200mm.

W przypadku zwykłych skrzydeł przekraczających 2,5 m lub skrzydeł pełnych powyżej 2,0 m należy zainstalować elektryczny zamek.

1

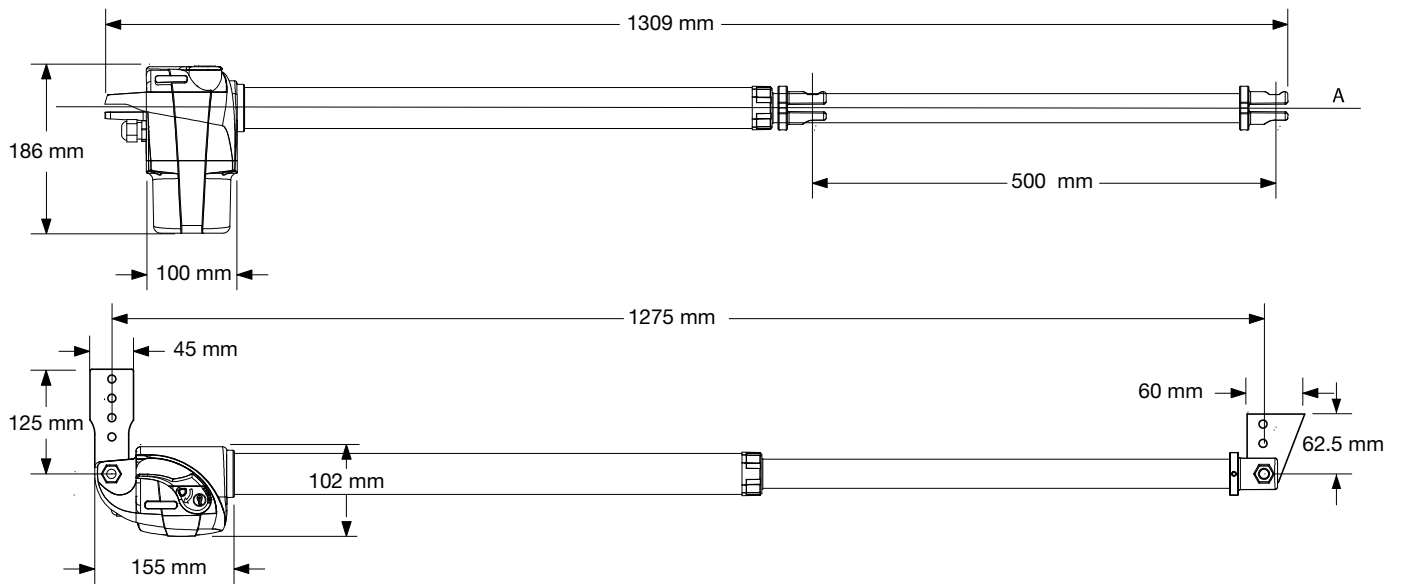

2

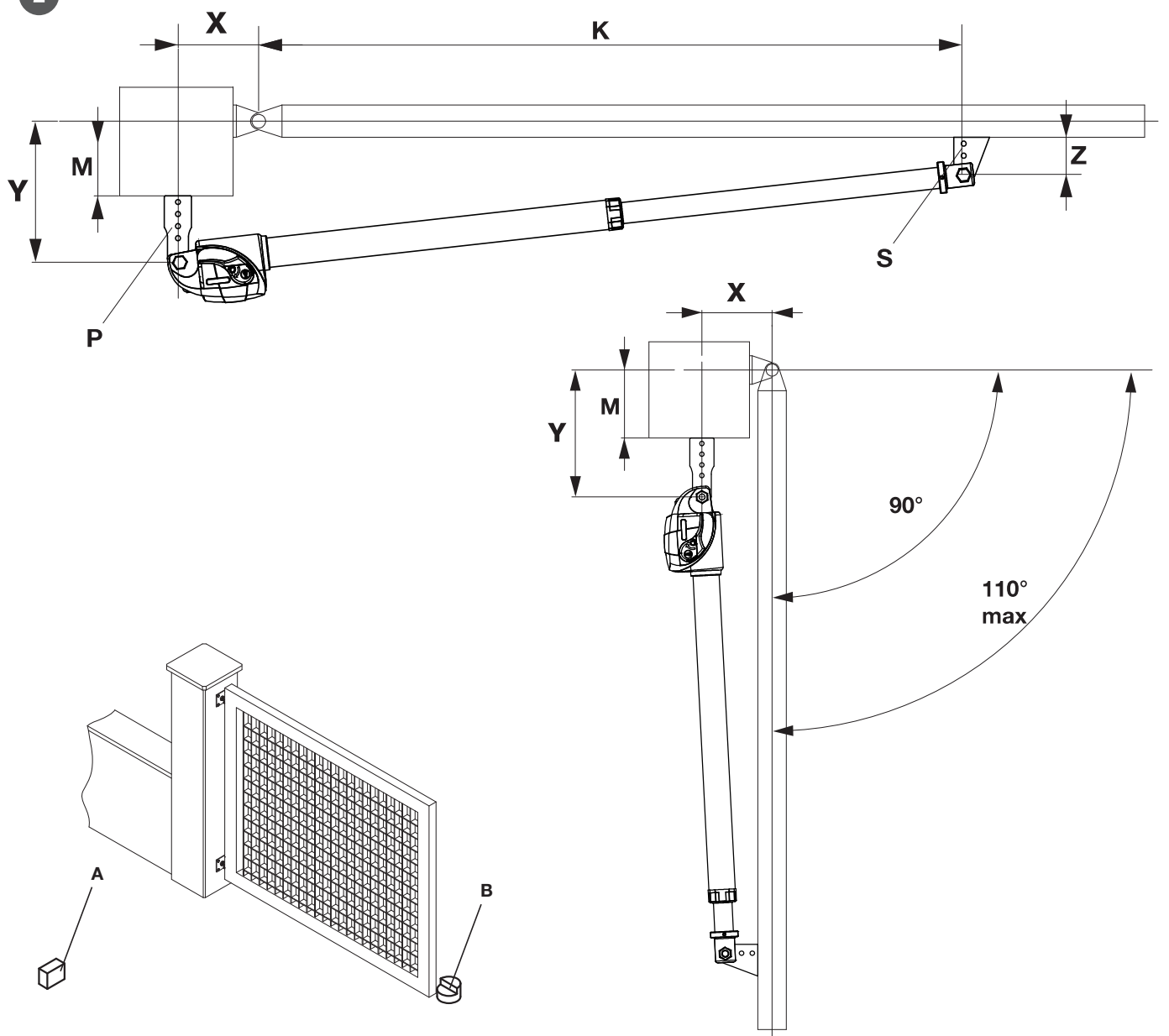

Apertura max Max Opening Max. Öffung Ouverture max Abiertura max.	X	Y	Z min	K	M max.	Tempo apertura / Opening time Öffungszeit / Temps d'ouverture Tiempo de abiertura / Prędkość kątowna		
						BILL 50 M/MA 50 Hz	BILL 50 ML 50 Hz	BILL 50 M/MA 60 Hz
90° 100° 110°	120	120	35	1154	80	16" 17,5" 18,5"	25" 27" 29"	10,8" 11,6" 12,5"
90° 100° 110°	160	160	35	1111	115	21,5" 23,5" 25"	33" 36,5" 39"	14,1" 15,8" 16,6"
90° 100° 110°	200	200	35	1067	150	26,5" 29" 31"	41" 45" 48"	17,9" 19,5" 20,8"
90° 100°	230	230	35	1033	175	30,5" 33,5"	47" 52"	20,4" 22,5"
90°	250	250	35	1010	190	33"	51"	22,0"

I tempi di apertura sono da considerare indicativi, in quanto dipendenti dalle condizioni di installazione.

The opening time is to be deemed as indicative as they depend on installation conditions.

Die Öffnungszeiten sind als Orientierungshilfe zu verstehen, da sie von den Installationsbedingungen abhängig sind.

Les temps d'ouverture doivent être considérés indicatifs, car ils dépendent des conditions d'installation.

Los tiempos de apertura son a considerar como aproximados ya que dependen de las condiciones de instalación.

Podany czas otwierania należy uważać za orientacyjny, gdyż zależy on od warunków instalacyjnych.

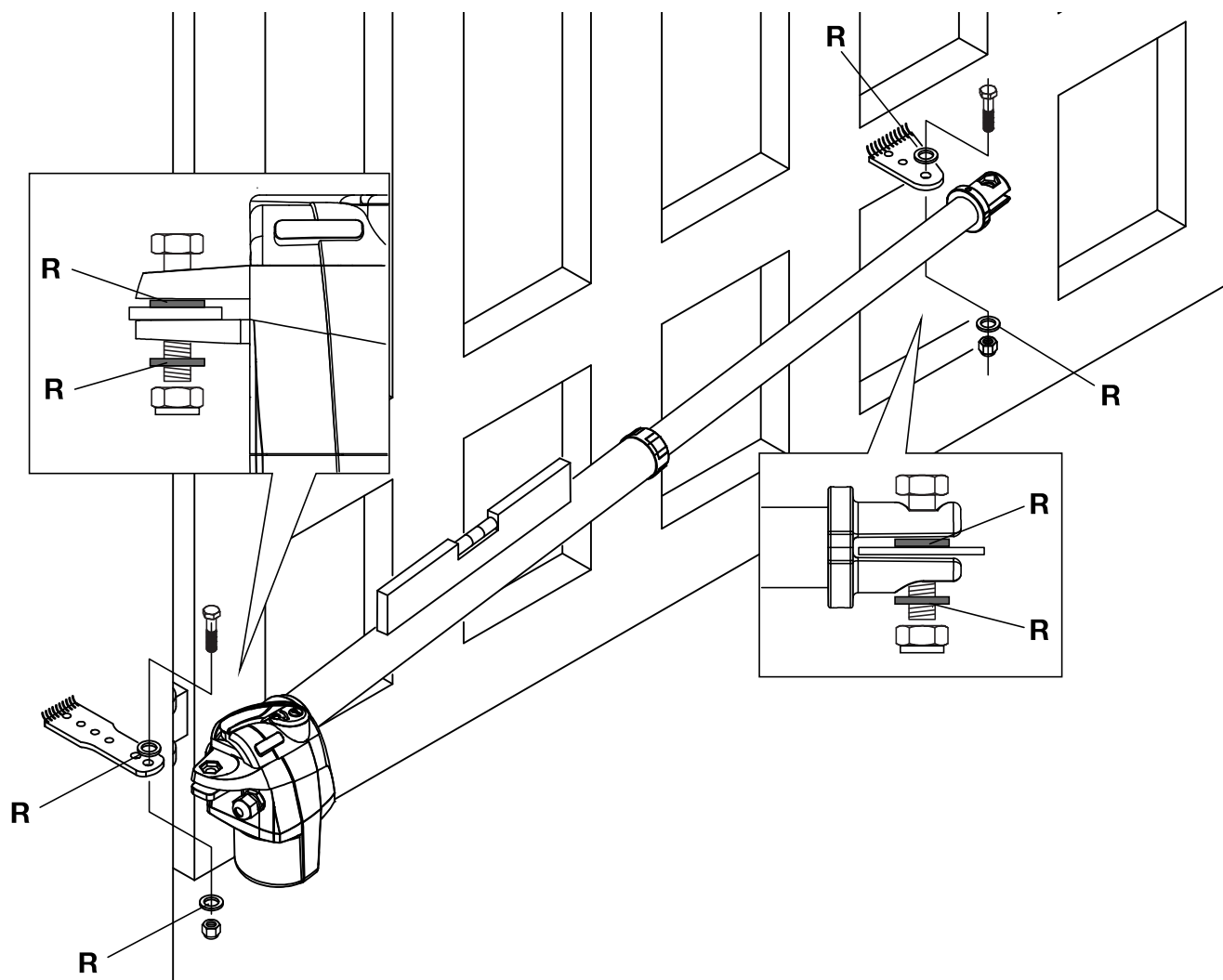

Collegamenti elettrici / **Wire diagram** / *Elektrische Anschlüsse*
Branchements électriques / Conexiones eléctricas / **Połączenia elektryczne**

Légende:

- 1 Moteur-réducteur BILL
- 2 Photocellule
- 3 Selecteur à clé (d'extérieur) ou clavier digital
- 4 Clignotant
- 5 Centrale électronique.

Legenda:

- 1 Motorreductor BILL
- 2 Fococélulas
- 3 Selectores a llave (de superficie).
- 4 Relampagueador.
- 5 Central electrónica.

Objaśnienia:

- 1 Siłownik BILL
- 2 Fotokomórki
- 3 Przełącznik kluczowy (zewnętrzny) lub panel z przyciskami
- 4 Światło migające
- 5 Centralka elektroniczna

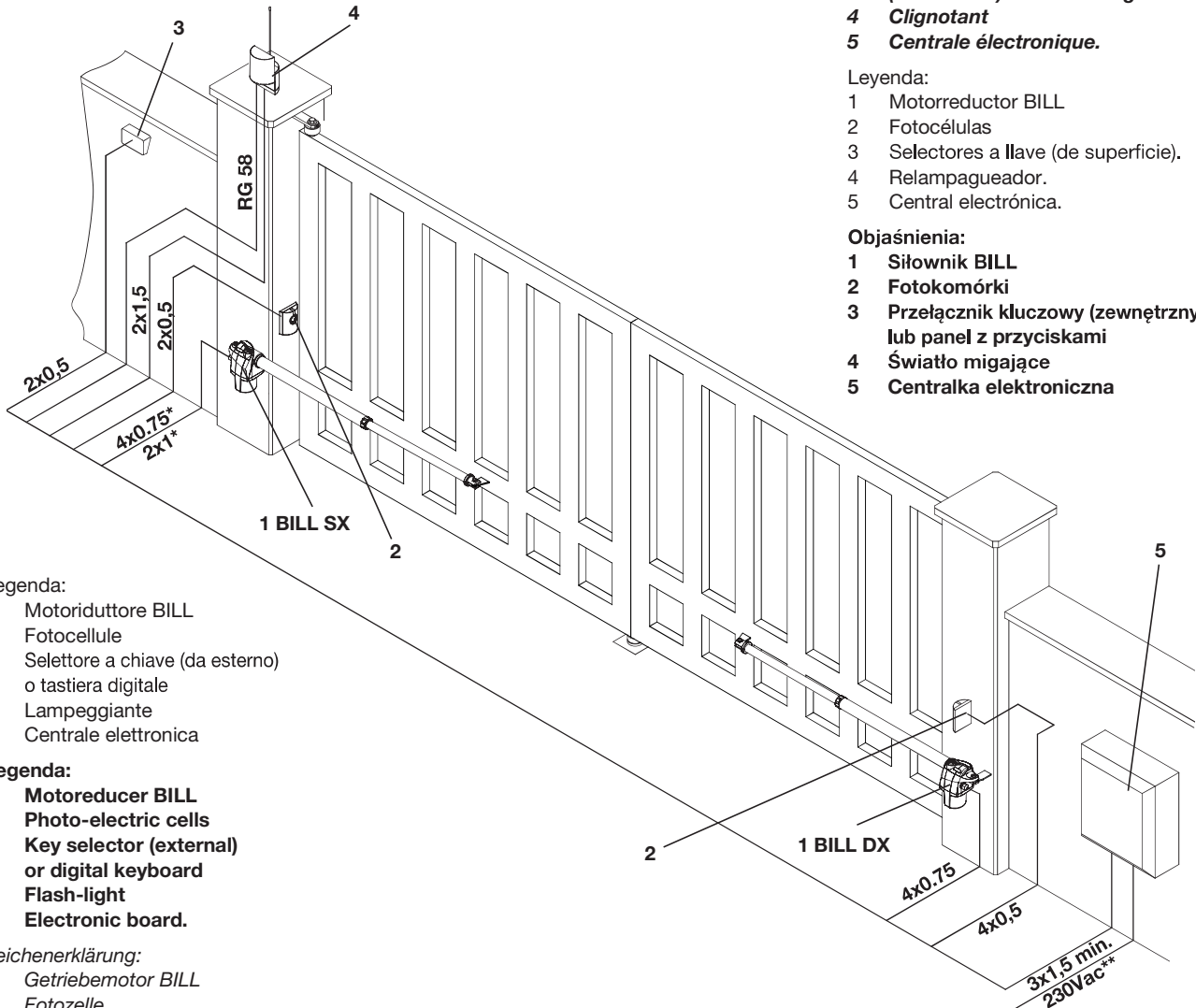

Legenda:

- 1 Motoriduttore BILL
- 2 Fotocellule
- 3 Selettore a chiave (da esterno) o tastiera digitale
- 4 Lampeggiante
- 5 Centrale elettronica

Legenda:

- 1 Motoreducer BILL
- 2 Photo-electric cells
- 3 Key selector (external) or digital keyboard
- 4 Flash-light
- 5 Electronic board.

Zeichenerklärung:

- 1 Getriebemotor BILL
- 2 Fozelle
- 3 Schlüssel-Selektor (außenliegend) oder Digital-Tastatur
- 4 Blinker I
- 5 Elektroschrank.

Tenere separati i cavi di potenza da quelli ausiliari.

* 115 Vac per la versione BILL30MA.

The power cables must be kept separated from the auxiliary cables.

*** 115 Vac for the BILL50MA model.**

Leistungskabel von Hilfskabeln getrennt halten.

* 115 Vac für Ausführung BILL50MA.

Séparer les câbles de puissance des câbles auxiliaires.

*** 115 Vac pour la version BILL 50MA.**

Tener separados los cables de potencia de los auxiliares.

* 115 Vac para la versión BILL50MA.

Należy trzymać w oddali przewody zasilania od przewodów pomocniczych.

*** 115 Vac dla wersji BILL50MA.**

GENERAL INFORMATIONS

The product shall not be used for purposes or in ways other than those for which the product is intended for and as described in this manual. Incorrect uses can damage the product and cause injuries and damages.
The company shall not be deemed responsible for the non-compliance with a good manufacture technique of gates as well as for any deformation, which might occur during use.
Keep this manual for further use.

INSTALLER GUIDE

This manual has been especially written to be use by qualified fitters.
Installation must be carried out by qualified personnel (professional installer, according to EN 12635), in compliance with Good Practice and current code.
Make sure that the structure of the gate is suitable for automation.
The installer must supply all information on the automatic, manual and emergency operation of the automatic system and supply the end user with instructions for use.

GENERAL WARNINGS

Packaging must be kept out of reach of children, as it can be hazardous.
For disposal, packaging must be divided the various types of waste (e.g. carton board, polystyrene) in compliance with regulations in force. Do not allow children to play with the fixed control devices of the product.
Keep the remote controls out of reach of children.
This product is not to be used by persons (including children) with reduced physical, sensory or mental capacity, or who are unfamiliar with such equipment, unless under the supervision of or following training by persons responsible for their safety.
Apply all safety devices (photocells, safety edges, etc.) required to keep the area free of impact, crushing, dragging and shearing hazard. Bear in mind the standards and directives in force, Good Practice criteria, intended use, the installation environment, the operating logic of the system and forces generated by the automated system.
Installation must be carried out using safety devices and controls that meet standards EN 12978 and EN 12453.
Only use original accessories and spare parts, use of non-original spare parts will cause the warranty planned to cover the products to become null and void.
All the mechanical and electrical parts composing automation must meet the requirements of the standards in force and outlined by CE marking.

ELECTRICAL SAFETY

An omnipolar switch/section switch with remote contact opening equal to, or higher than 3mm must be provided on the power supply mains. Make sure that before wiring an adequate differential switch and an overcurrent protection is provided.
Pursuant to safety regulations in force, some types of installation require that the gate connection be earthed.
During installation, maintenance and repair, cut off power supply before accessing to live parts.
Also disconnect buffer batteries, if any are connected.
The electrical installation and the operating logic must comply with the regulations in force.
The leads fed with different voltages must be physically separate, or they must be suitably insulated with additional insulation of at least 1 mm.
The leads must be secured with an additional fixture near the terminals.
During installation, maintenance and repair, interrupt the power supply before opening the lid to access the electrical parts
Check all the connections again before switching on the power.
The unused N.C. inputs must be bridged.

WASTE DISPOSAL

As indicated by the symbol shown, it is forbidden to dispose this product as normal urban waste as some parts might be harmful for environment and human health, if they are disposed of incorrectly.
Therefore, the device should be disposed in special collection platforms or given back to the reseller if a new and similar device is purchased.
An incorrect disposal of the device will result in fines applied to the user, as provided for by regulations in force.

Descriptions and figures in this manual are not binding. While leaving the essential characteristics of the product unchanged, the manufacturer reserves the right to modify the same under the technical, design or commercial point of view without necessarily update this manual.

1) INTRODUCTION

Electromechanical operator to activate swing gates, available in the following models:

BILL50M: with motor powered at 230 VAC.

BILL50MA: with motor powered at 115 VAC.

For 5very model, the RGHT (DX) version is also available to install the system on the right gate leaf, and the LFT (SX) version is available for installation on the left gate leaf.

In case of doubt, as shown in the instruction manual, the wording DX (right) or SX (left), which identifies the different models, can be seen by opening the release handle.

For simplicity reasons, this manual shows the SX motor for left gate leaves. For the DX (right) versions, installation dimensions and instructions are the same. The main dimensions are shown in Fig. 1.

- Before installing the system, read the instruction herein.
- It is mandatory not to use the BILL 50 item for applications different from those indicated in the instructions herein.
- Supply the end user with instructions for using this system.
- The end user should receive special instruction manual.
- All Benincà items are covered by an insurance policy for damages and injuries caused by manufacture faults. It is however required that the machine bear the CE marking and original Benincà parts be used.

2) GENERAL INFORMATION

To ensure a good operation of these automatic devices, the gate to be automated should meet the following requirements:

- good strength and stiffness.
- hinges should have a minimum backlash and allow for smooth and regular manual operations.
- when closed, the gate leaves should correctly overlap for their entire height.

Warning: BILL50 is not equipped with electric limit switches or mechanical stoppers. It is mandatory that the gate leaf be equipped with mechanical stoppers fitted to the ground (Fig.2 ref. A and B).

3) TECHNICAL DATA

	BILL 50M	BILL 50MA	BILL 50ML
Motor power supply	230Vac 50/60Hz	115 Vac 50/60Hz	230Vac 50/60Hz
Absorbed rating	240W		265 W
Consumption	1,1 A	2,2 A	1,2 A
Max. thrust	2800 N		3100 N
Operating jogging	30 %		
Protection level	IP54		
Operating temperature	-20°C / +50°C		
Capacitor	8 µF	31,5 µF	8 µF
Useful stroke	500 mm		
Noise	<70 dB		
Lubrication	Permanent grease		
Weight	6,3 kg		

4) OPERATING LIMITS

The following tables show the permitted maximum weight and width figures of the gate leaves.

BILL 50M / BILL 50MA						
Max gate leaf weight (kg)	--	100	200	300	450	550
Max gate leaf (m)	4,5	4,0	3,5	3,0	2,5	2,1
BILL 50ML						
Max gate leaf weight (kg)	100	150	250	350	500	650
Max gate leaf (m)	4,5	4,0	3,5	3,0	2,5	2,1

In case of wind effect the limits can be significantly reduced.

IMPORTANT: The electric lock is essential in the event of standard gate leaves wider than 2.5m and of solid gate leaves wider than 2.0m.

5) HOW TO INSTALL THE SYSTEM

- 1) Define the height of the system from ground (the most centred possible with respect to the main door and corresponding to a rugged crossbeam).
- 2) Weld the P plate, taking account of figures X and Y of Fig. 2/3.
- 3) Release the actuator, as shown in the instruction manual. When the gate is closing, temporarily lock the S* bracket by keeping the K measure as per Fig. 2/3. In these conditions, the actuator must not be positioned entirely at end of stroke, but 10mm extra-stroke should be still available. By manually opening the gate leaf, check that the actuator does not hit the leaf or the pillar.
- 4) Only after this check, carry out the final welding of the S bracket. The actuator should be perfectly flat.

Important: the respect of dimensions indicated in Fig. 3 ensures the optimal operation of the automatic system. These different dimensions may cause malfunctions.

In any case, the manufacturer shall be held unharmed with respect to damages caused by the non-respect of the dimensions indicated.

If it is not possible to carry out welding, adjustable brackets, which can be mounted by using screws (art B.SR), are available as optional accessory.

Fix the actuator to the bracket by means of screws and nuts supplied. Use washers as shown in Fig. 4.

Note: The difference between measures X and Y shall be never exceed 40mm. Greater differences cause the unsmooth movement of the gate.

Dimensions M and X should be carefully checked to avert that the actuator hits the pillar (dim. M) or the leaf (dim. Z).

The total stroke of the actuator is around 520mm. The stroke, however, cannot be entirely used. An extra stroke of around 10 mm should be always provided both in the closing and opening phases.

** In the BILL 50 geared motor, the difference in height of brackets P and S shall be nil. These brackets should be therefore fitted at the same height (Fig. 1, ref. A)*

6) WIRE CONNECTIONS

BILL 50 is supplied with a pre-cabled wire, around 80 cm long, to be connected to the junction box fitted to the pillar:

BLACK Gear 1

BROWN Gear 2

GREY Motor, common

Yellow/Green Earth

Note:

The motor cable shall be replaced only by an authorised assistance centre.

IT IS MANDATORY to connect the system to ground by using the special GND terminal, as provided by regulations in force.

WARNING

The insurance policy, which covers any damages or injuries caused by manufacture faults, requires that the installation comply with regulations in force and Benincà original accessories be used.

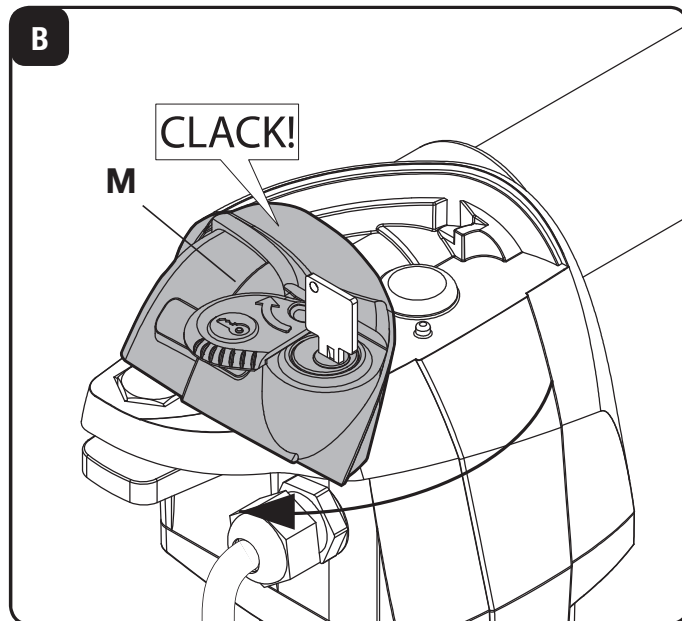
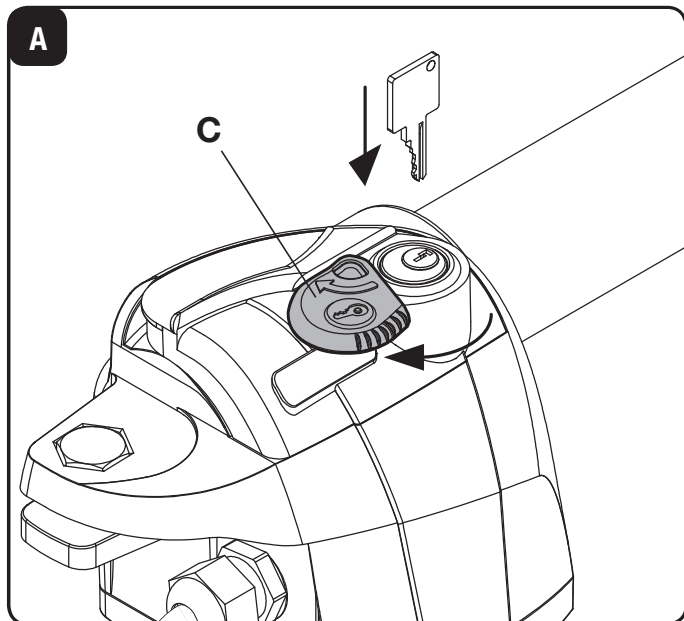

ITALIANO

Norme di sicurezza

- Non sostare nella zona di movimento della porta.
- Non lasciare che i bambini giochino con i comandi o in prossimità delle ante.
- In caso di anomalie di funzionamento non tentare di riparare il guasto ma avvertire un tecnico specializzato.

Manovra manuale e d'emergenza

In caso di mancanza dell'energia elettrica o di guasto, per azionare manualmente le ante procedere come segue:

- ruotare lo sportellino copri serratura (fig. A - rif.C);
- Inserire la chiave di sblocco fornita in dotazione e ruotarla di 90°, in senso antiorario per il motore a sinistra in senso orario per il motore a destra;
- ruotare la maniglia di sblocco come indicato in figura B (rif. M); la leva ha una posizione iniziale di stop, che va oltrepassata (clack!) per iniziare ad agire effettivamente sullo sblocco meccanico;
- portare la leva in posizione di completa apertura (circa 90° di rotazione) nella parte finale la leva opporrà una leggera resistenza.
- è ora possibile manovrare manualmente l'anta;
- per ripristinare il funzionamento automatico, riportare la maniglia nella posizione iniziale, ruotare la chiave di 90° e richiudere lo sportellino copri-serratura.

Manutenzione

- Controllare periodicamente l'efficienza dello sblocco manuale di emergenza.
- Astenersi assolutamente dal tentativo di effettuare riparazioni, potreste incorrere in incidenti; per queste operazioni contattare un tecnico specializzato.
- L'attuatore non richiede manutenzioni ordinarie, tuttavia è necessario verificare periodicamente l'efficienza dei dispositivi di sicurezza e le altre parti dell'impianto che potrebbero creare pericoli in seguito ad usura.

Smaltimento

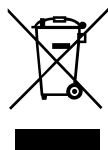

Come indicato dal simbolo a lato, è vietato gettare questo prodotto nei rifiuti domestici in quanto alcune parti che lo compongono potrebbero risultare nocive per l'ambiente e la salute umana, se smaltite scorrettamente. L'apparecchiatura, pertanto, dovrà essere consegnata in adeguati centri di raccolta differenziata, oppure riconsegnata al rivenditore al momento dell'acquisto di una nuova apparecchiatura equivalente. Lo smaltimento abusivo del prodotto da parte dell'utente comporta l'applicazione delle sanzioni amministrative previste dalla normativa vigente.

Attenzione

Tutti i prodotti Benincà sono coperti da polizza assicurativa che risponde di eventuali danni a cose o persone causati da difetti di fabbricazione, richiede però la marcatura CE della "macchina" e l'utilizzo di componenti originali Benincà.



Safety rules

- Do not stand in the movement area of the door.
- Do not let children play with controls and near the door.
- Should operating faults occur, do not attempt to repair the fault but call a qualified technician.

Manual and emergency operation

In the event of power failure or faults, the gate can be manually operated as follows:

- turn the door covering the lock (Fig. A. – ref. C);
- Introduce the release key supplied and turn it by 90° anti-clockwise for the left motor, and clockwise for the right motor;
- turn the release handle, as indicated in figure B (ref. M); the lever has a stop initial position that must be overcome (click to be heard) to actually act on the mechanical release;
- move the lever to totally open position (around 90° rotation). Towards the end, the lever movement will be slightly stiffer.
- the gate leaf can be opened or closed by hand;
- to reset the automatic operation, move the handle to the initial position, turn the key by 90° and close the door covering the lock.

Maintenance

- Every month check the good operation of the emergency manual release.
- It is mandatory not to carry out extraordinary maintenance or repairs as accidents may be caused. These operations must be carried out by qualified personnel only.
- The operator is maintenance free but it is necessary to check periodically if the safety devices and the other components of the automation system work properly. Wear and tear of some components could cause dangers.

Waste disposal

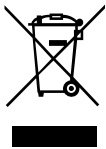

As indicated by the symbol shown, it is forbidden to dispose this product as normal urban waste as some parts might be harmful for environment and human health, if they are disposed of incorrectly. Therefore, the device should be disposed in special collection platforms or given back to the reseller if a new and similar device is purchased. An incorrect disposal of the device will result in fines applied to the user, as provided for by regulations in force.

Warning

All Benincá products are covered by insurance policy for any possible damages to objects and persons caused by construction faults under condition that the entire system be marked CE and only Benincá parts be used.

Sicherheitsvorschriften

- Nicht im Öffnungsbereich verweilen.
- Kinder nicht mit den Steuerungen oder in der Nähe des Tores spielen lassen.
- Bei Funktionsausfällen nicht versuchen, den Schaden selber zu beheben, sondern den Techniker rufen.

Hand- und Notbedienung

Bei einem Stromausfall oder im Falle einer Störung, kann der Torflügel folgendermaßen von Hand gesteuert werden:

- Die Schloss-Verschlussklappe nach außen drehen (Abb. A, Ref. C)
- Den speziellen Entsicherungsschlüssel (mitgeliefert) einstecken und um 90° gegen den Uhrzeigersinn bei linkem Motor oder im Uhrzeigersinn bei rechtem Motor drehen
- Den Entsicherungsriff wie in Abbildung B (Ref. M) gezeigt, drehen. Der Hebel hat eine Ausgangs- bzw. Stopposition, die überschritten werden muss (Klick!), um die Mechanik zu entsichern.
- Den Hebel vollkommen öffnen (um ca. 90° drehen). Gegen Ende ist ein leichter Widerstand zu bemerken.
- Nun kann der Torflügel von Hand geöffnet bzw. geschlossen werden.
- Um den automatischen Betrieb wieder herzustellen, den Hebel in die Ausgangsposition zurück bringen und den Schlüssen um 90° drehen. Die Verschlussklappe des Schlosses wieder schließen.

Wartung

- Monatliche Kontrolle der manuellen Notentriegelung
- Es ist absolut untersagt, selbstständig Sonderwartung oder Reparaturen vorzunehmen, da Unfälle die Folge sein können; wenden Sie sich an den Techniker.
- Der Antrieb braucht keine ordentliche Unterhaltung aber es ist periodisch notwendig die Leistungsfähigkeit der Sicherheitsvorrichtungen und die andere Teile des Anlages zu prüfen. Sie könnten durch Abnutzung Gefahr hervorbringen.

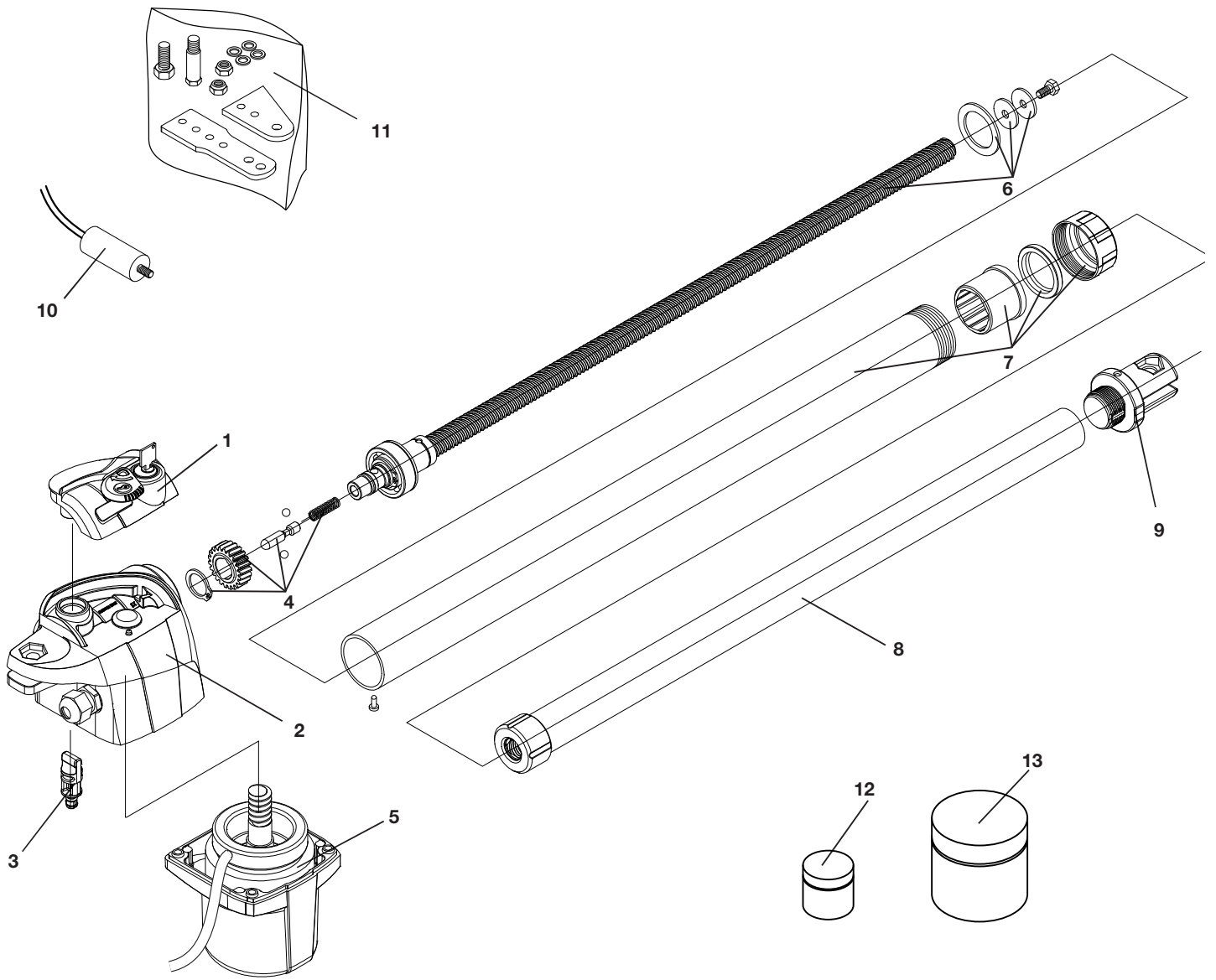

Ref.	BILL 50M DX Code	BILL 50M SX Code	BILL 50MA DX Code	BILL 50MA SX Code	BILL 50ML DX Code	BILL 50ML SX Code	NOTE
1	9686591	9686592	9686591	9686592	9686591	9686592	
2	9686593	9686594	9686593	9686594	9686593	9686594	
3	9686595	9686595	9686595	9686595	9686595	9686595	
4	9686596	9686596	9686596	9686596	9686596	9686596	
5	9688175	9688175	9688176	9688176	9688177	9688177	
6	9688179	9688179	9688179	9688179	9688179	9688179	
7	9688118	9688118	9688118	9688118	9688118	9688118	
8	9688114	9688114	9688114	9688114	9688114	9688114	
9	9688116	9688116	9688116	9688116	9688116	9688116	
10	9688181	9688181	9686569	9686569	9688181	9688181	
11	9686652	9686652	9686652	9686652	9686652	9686652	
12	9688125	9688125	9688125	9688125	9688125	9688125	BENINCA PASTE TS5000 use with ref.7
13	9688126	9688126	9688126	9688126	9688126	9688126	BENINCA PLEX2TL use with ref.4/5/8

Dichiarazione di Conformità UE (DoC)

Nome del produttore: **Automatismi Benincà SpA**
Indirizzo: **Via Capitello, 45 - 36066 Sandrigo (VI) - Italia**
Telefono: **+39 0444 751030** Indirizzo e-mail: **sales@beninca.it**

Persona autorizzata a costruire la documentazione tecnica:
Automatismi Benincà SpA
Tipo di prodotto: **automazione per cancelli battenti**
Modello/Tipo: **BILL 50M - BILL 50MA**
Accessori: **N/A**

Il sottoscritto Luigi Benincà, in qualità di Responsabile Legale, dichiara sotto la propria responsabilità che il prodotto sopraindicato risulta conforme alle disposizioni imposte dalle seguenti direttive:

Direttiva 2014/30/UE del Parlamento europeo e del Consiglio, del 26 febbraio 2014, concernente l'armonizzazione delle legislazioni degli Stati membri relative alla compatibilità elettromagnetica (**EMCD**), secondo le seguenti norme armonizzate:

EN 61000-6-2:2005, EN 61000-6-3:2007.

Direttiva 2011/65/UE del Parlamento europeo e del Consiglio, dell' 8 giugno 2011, sulla restrizione dell'uso di determinate sostanze pericolose nelle apparecchiature elettriche ed elettroniche (**RoHS**), secondo le seguenti norme armonizzate:

EN 50581:2012

Benincà Luigi, Responsabile legale.
Sandrigo, 18/01/2017.



Il Certificato di Conformità di questo documento corrisponde all'ultima revisione disponibile al momento della stampa e può risultare differente per esigenze editoriali dall'originale disponibile presso il produttore.

Il Certificato di Conformità più completo e recente è disponibile consultando il sito: www.beninca.com oppure può essere richiesto presso:
Automatismi Benincà S.p.A - Sandrigo VI - Italy.

UE Declaration of Conformity (DoC)

Manufacturer's name: **Automatismi Benincà SpA**
Address: **Via Capitello, 45 - 36066 Sandrigo (VI) - Italia**
Telephone: **+39 0444 751030** Email address: **sales@beninca.it**

Person authorised to draft the technical documentation:
Automatismi Benincà SpA
Product type: **operator for hinged gates**
Model/type: **BILL 50M - BILL 50MA**
Accessories: **N/A**

The undersigned Luigi Benincà, as the Legal Officer, declares under his liability that the aforementioned product complies with the provisions established by the following directives:

Directive 2014/30/UE OF THE EUROPEAN PARLIAMENT AND OF THE COUNCIL of 26 February 2014, on the harmonisation of the laws of Member States relating to electromagnetic compatibility, according to the following harmonised regulations:

EN 61000-6-2:2005, EN 61000-6-3:2007 + A1:2011.

Directive 2011/65/EU of the European Parliament and Council, dated 8 June 2011, on the restricted use of certain hazardous substances in electrical and electronic devices (**RoHS**), according to the following standards:

EN 50581:2012

Benincà Luigi, Legal Officer.
Sandrigo, 18/01/2017.

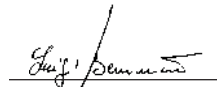

The certificate of conformity in this document corresponds to the last review available at the time of printing and could differ for editorial requirements from the original available from the manufacturer.

The most recent and complete certificate of conformity is available consulting the site: www.beninca.com or can be requested from:
Automatismi Benincà SpA - Sandrigo VI - ITALY.

EG-Konformitätserklärung (DoC)

Name des Herstellers: **Automatismi Benincà SpA**
Adresse: **Via Capitello, 45 - 36066 Sandrigo (VI) - Italia**
Telefon: **+39 0444 751030** E-Mail-Adresse: **sales@beninca.it**

Zur Erstellung der technischen Dokumentation berechtigte Person: **Automatismi Benincà SpA**
Produkttypus: **Antriebe für Drehflügel Tore**
Modell/Typus: **BILL 50M - BILL 50MA**
Zubehör: **N/A**

Der Unterzeichnete Luigi Benincà, in seiner Eigenschaft als Rechtsvertreter, erklärt eigenverantwortlich, dass das oben angegebene Produkt den durch die folgenden Richtlinien vorgegebene Bestimmungen entspricht:

Richtlinie 2014/30/UE DES EUROPÄISCHEN PARLAMENTES UND DES RATES vom 26. Februar 2014 zur Angleichung der Rechtsvorschriften der Mitgliedstaaten über die elektromagnetische Verträglichkeit, gemäß nachstehenden Normen:

EN 61000-6-2:2005, EN 61000-6-3:2007 + A1:2011.

Richtlinie 2011/65/EU des Europäischen Parlaments und des Rates vom 8. Juni 2011 zur Beschränkung der Verwendung bestimmter gefährlicher Stoffe in Elektro- und Elektronikgeräten (**RoHS**), gemäß den folgenden harmonisierten Normen:

EN 50581:2012

Benincà Luigi, Rechtsvertreter.
Sandrigo, 18/01/2017.

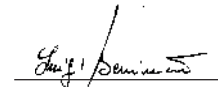

Die in diesem Dokument vorliegende Konformitätserklärung entspricht der neuesten zum Druckzeitpunkt erhältlichen Revision und könnte aufgrund von verlegerischen Gründen vom beim Hersteller erhältlichen Original abweichen.

Die neueste und vollständigste Konformitätserklärung ist auf der Internetseite: www.beninca.com erhältlich oder kann bei folgender Adresse angefordert werden:
Automatismi Benincà SpA - Sandrigo VI - ITALY.

Déclaration CE de conformité (DoC)

Nom du producteur : **Automatismi Benincà SpA**
Adresse : **Via Capitello, 45 - 36066 Sandrigo (VI) - Italia**
Téléphone : **+39 0444 751030** Adresse e-mail : **sales@beninca.it**
Personne autorisée à construire la documentation technique : **Automatismi Benincà SpA**
Type de produit : **automatization pour portails ouvrants**
Modèle/Type: **BILL 50M - BILL 50MA**
Accessoires : **N/A**

Le soussigné Luigi Benincà, en sa qualité de Représentant Légal, déclare sous sa propre responsabilité que le produit indiqué ci-dessus est conforme aux dispositions imposées par les directives suivantes:

Directive 2014/30/UE DU PARLEMENT EUROPÉEN ET DU CONSEIL du 26 février 2014 concernant le rapprochement des législations des États membres relatives à la compatibilité électromagnétique, selon les suivantes normes harmonisées:

EN 61000-6-2:2005, EN 61000-6-3:2007 + A1:2011.

Directive 2011/65/UE du Parlement européen et du Conseil, du 8 juin 2011, sur la restriction à l'usage de substances dangereuses déterminées dans les appareils électriques et électroniques (**RoHS**), selon les normes harmonisées suivantes :

EN 50581:2012

Benincà Luigi, Représentant Légal.
Sandrigo, 18/01/2017.

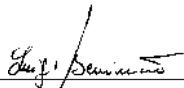

Le certificat de conformité présent dans ce document correspond à la dernière révision disponible au moment de l'impression et pourrait différer pour des exigences éditoriales de l'original disponible chez le constructeur.

Le certificat de conformité le plus récent et complet est disponible en consultant le site : www.beninca.com ou peut être demandé à :
Automatismi Benincà SpA - Sandrigo VI - ITALIE.

Declaración CE de conformidad (DoC)

Nombre del productor: **Automatismi Benincà SpA**
Dirección: **Via Capitello, 45 - 36066 Sandrigo (VI) - Italia**
Teléfono: **+39 0444 751030** Dirección de correo electrónico: **sales@beninca.it**
Persona autorizada a producir la documentación técnica: **Automatismi Benincà SpA**
Tipo de producto: **automatización para cancelas de batiente**
Modelo/Tipo: **BILL 50M - BILL 50MA**
Accesorios: **N/A**

El infrascrito Luigi Benincà, en calidad de Representante Legal, declara bajo su responsabilidad que el producto anteriormente mencionado resulta en conformidad con las disposiciones establecidas por las siguientes directivas:

Directiva 2014/30/UE del parlamento europeo y del consejo del 26 de febrero de 2014 sobre la aproximación de las legislaciones de los Estados miembros con relación a la compatibilidad electromagnética, según las siguientes normas armonizadas:

EN 61000-6-2:2005, EN 61000-6-3:2007.

Directiva 2011/65/UE del Parlamento europeo e del Consejo, de 8 de junio de 2011, sobre restricciones a la utilización de determinadas sustancias peligrosas en aparatos eléctricos y electrónicos (**RoHS**), según las normas siguientes armonizadas:

EN 50581:2012

Benincà Luigi, Representante Legal.
Sandrigo, 18/01/2017

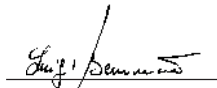

El certificado de conformidad presente en este documento corresponde a la última revisión disponible en el momento de la impresión y podría diferir por exigencias editoriales del original disponible en la sede del fabricante.

El certificado de conformidad más reciente y completo está disponible consultando el sitio: www.beninca.com o se puede solicitar a:
Automatismi Benincà SpA - Sandrigo VI - ITALY.

Deklaracja zgodności CE (DoC)

Nazwa producenta: **Automatismi Benincà SpA**
Adres: **Via Capitello, 45 - 36066 Sandrigo (VI) - Italia**
Telefon: **+39 0444 751030** Adres e-mail: **sales@beninca.it**
Osoba upoważniona do stworzenia dokumentacji technicznej: **Automatismi Benincà SpA**
Rodzaj produktu: **Automatyzm do bram uchylnych**
Model/Typ: **BILL 50M - BILL 50MA**
Akcesoria: **N/A**

Niżej podpisany/a Luigi Benincà, jako Przedstawiciel prawny, deklaruje na własną odpowiedzialność, że wskazany produkt jest zgodny z rozporządzeniami następujących dyrektyw:

Dyrektywy 2014/30/WE rady I parlamentu europejskiego z dnia 26 lutego 2014r. w sprawie zbliżenia ustawodawstwa państw członkowskich w zakresie kompatybilności elektromagnetycznej, zgodnie z następującymi normami zharmonizowanymi:

EN 61000-6-2:2005, EN 61000-6-3:2007 + A1:2011.

Dyrektywa 2011/65/WE Parlamentu Europejskiego i Rady z 8 czerwca 2011 r. w sprawie ograniczenia stosowania niektórych niebezpiecznych substancji w sprzęcie elektrycznym i elektronicznym (**RoHS**), zgodnie z poniższymi normami zharmonizowanymi:

EN 50581:2012

Benincà Luigi, Przedstawiciel prawny.
Sandrigo, 18/01/2017.

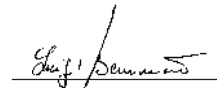

Certyfikat zgodności znajdujący się w niniejszym dokumencie odpowiada ostatniej aktualizacji dostępnej w momencie wydruku i może się różnić ze względu na wydawniczych od oryginału dostępnego u producenta.

Najbardziej aktualny i kompletny certyfikat zgodności jest dostępny na stronie: www.beninca.com lub można się po niego zwrócić do:
Automatismi Benincà SpA - Sandrigo VI - WŁOCHY.

BENINCA®